

**INDIAN INSTITUTE OF TECHNOLOGY-KANPUR
(DEPARTMENT OF MECHANICAL ENGINEERING)**

Subject: Request for Uploading the Tender Document on institute web site.
Enquiry NO: PM/NET-ME/2013-2014-06 closing date: 27th September 2013

Through: Head, Mechanical Engineering.

Sealed Quotations (technical bid and price bid separately sealed) are invited by the undersigned for the supply of following items.

Name of Item: Visible light tomography set-up:

The main components required to set up the visible light tomography system on a compact plasma (low temperature, and microwave excited) are following –

1. Optical interference filters (25 nos.)
2. Collimator (25 nos.)
3. CMOS linear image sensor (25nos.)
4. Microcontroller chip (25 nos.)
5. MUX and DMUX chip
6. Data acquisition system (DAQ)
7. Power supply, trigger, start pulse (I/P)
8. Adequate Cables
9. Computer and accessing programming
10. Optical fiber
11. Equipment for linear slider

Block diagram for experimental set-up

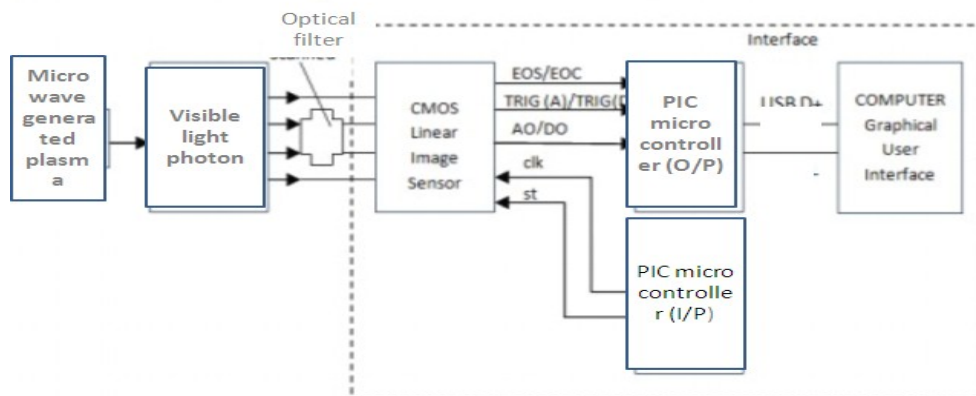

1. Optical interference filters:

1.1 Function:

Interference band pass filters is a wavelength selector. That allows transmission of a predetermined wavelength while rejecting other wavelengths.

1.2 Applications:

- Optical interference filters provide central wavelength peak value for H- α , H- β , and Ar 750nm, 764nm, 810nm gases in emission profile of electromagnetic radiations.
- It also inform about the Zeff profile and useful for understanding the current distribution and impurity distribution in the plasma.
- Spatial distribution of line radiation is used to obtain density and temperature distribution in plasma.

1.3 Specification:

a) Central Wavelength Tolerances

10 nm Bandpass Filters \pm 2 nm
 Broadband Filters \pm 15 nm
 NIR Bandpass FiltersVaries by wavelength

b) Transmittance (Standard Bandpass Filters):

450 nm to 647 nm \geq 45%
 650 nm to 1064 nm \geq 50%

c) Dimensional Tolerances

12.5 mm dia. +0.0/0.2 mm
 25 mm dia. +0.01-0.1 mm

d) Minimum Clear Aperture

12.5 mm dia.9.0 mm
 25.0 mm dia.21.0 mm

e) Mounting..... Black anodized metal ring

f) Thickness 7.5 mm +0.0/-0.2 mm

2. Collimator: Collimator is used to converge incoming visible light from plasma at the active area of photodiode and generate fan beam geometry for image processing. Collimator material could be Teflon or other material to remove beam hardening so that output signal would give high accuracy. Insulator material can avoid heating from sensor and other electronics part.

Specification:

- Circular size :
- Dia- 1.5 cm +0.1/-0.2 mm & thickness – 10 mm +0.0/ - 0.2 mm
- High temperature and pressure sustainable material
- Robust
- Remove beam hardening

3. CMOS linear image sensor:

Table 3.1 Present characteristics and specifications of detectors specifically for visible light tomography set-up for compact plasma diagnostics –

Specification require	value
-----------------------	-------

Detector dimensions	2 cm
Frequency bandwidth	190nm -1100 nm (specially H-α 656.3 nm H-β 486.1 nm , Ar 750.11, 763.16, 810.85 nm)
No of element in one photodiode array	100-200 photodiodes pixels (pitch 50 micron)
Packaging materials	Good absorber for light
Dark current	less
Output mode	Linear with generated charge (charge storage method)
Sensor accuracy	3-5 % tolerance at high temperature (>100 °C)
Driver circuit	Inbuilt
Output speed	16 bit
Application	Image input device and optical sensing device
Board material	Ceramic or quartz

4. Microcontroller: PIC microcontrollers combine a microprocessor, memory and interface onto a single chip, used as developing software-controlled electronic systems.

Specification

- Microcontroller is used as a driver to enable the operation of CMOS linear image sensor.
- Microcontroller should be control output signal of CMOS linear array with 16 bit size.

5. Multiplexer and Demultiplexer chip: Multiplexers (MUX) are mainly used to increase the amount of data that can be sent over the network within a certain amount of time and bandwidth. Conversely, a **demultiplexer (demux)** is a device taking a single input signal and selecting one of many data-output-lines, which is connected to the single input. A multiplexer is often used with a complementary demultiplexer on the receiving end.

Specification:

- Multiplexer/ Demultiplexer chip can read multiple input/output signals with fast speed. It can be reduces complexity of wire and circuitry.
- Time-division multiplexing
- 8 to 2 pin Multiplexer/ Demultiplexer chip
- Counting time should be very fast for each signal

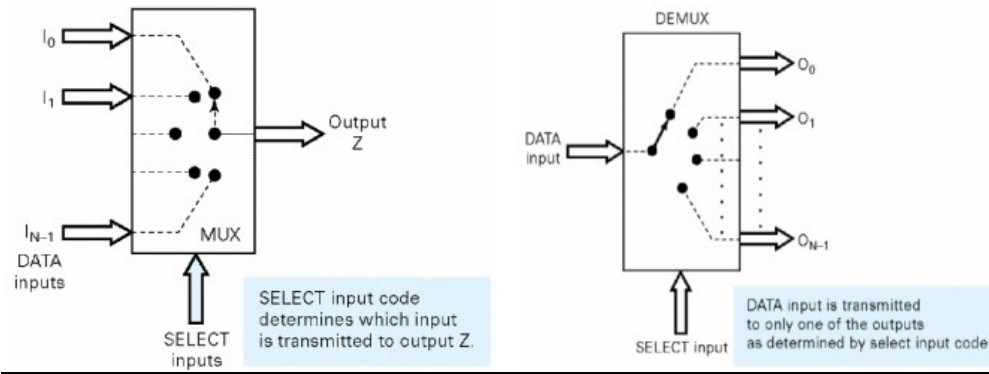

6. Optical fiber : Fiber specification requires for optical diagnostics of microwave induced plasma:

<u>Type of product</u>	<u>Total number (qty)</u>	<u>Wavelen gth</u>	<u>Fiber core diameter</u>	<u>Overall length</u>	<u>Jacketing</u>	<u>Other option</u>
Standard fiber	1(both ended SMA905 connector) & 1 (single ended SMA905 connector)	IR (350-2500 nm)	1000 μ m	3 meter	Kevlar reinforce PVS	HT (200 degree C)
Standard fiber	1(both ended SMA905) & 1 (single ended SMA905 connector)	UV (300-800 nm)	1000 μ m	3 meter	Kevlar reinforce PVC	HT(200 degree C)

7. Data acquisition system (DAQ):

- Ease of use—16-bit, 1 MSPS complete data acquisition system
- High impedance, 8-channel input: $>500 \text{ M}\Omega$
- Differential input voltage range: $\pm 24.576 \text{ V}$ maximum
- High input common-mode rejection $> 100 \text{ dB}$
- User programmable input ranges
- Channel sequencer with individual channel gains
- On-chip 4.096 V reference and buffer
- Auxiliary input – direct interface to PuLSAR ADC inputs
- No latency/pipeline delay (SAR architecture)
- Serial 4-wire, 1.8 V to 5 V SPI-/SPORT-compatible interface
- LFCSP package (6 mm \times 6 mm)
- -40°C to $+85^\circ\text{C}$ industrial temperature range

8. Power supply, trigger, start pulse (I/P source):

- 10 Volt power supply
- DC power supply
- Input trigger for CMOS sensor
- Start pulse for CMOS sensor
- Above mentioned components must have individual warranty of at least 1 year

9. Cables:

- High Temperature sustainable (100-200 °C)
- Data transfer speed for 16 bit input/output signals

10. Computer and accessing programming:

Specifications	Desktop
Processor	Intel Xeon Processor W3690 3.46 GHz, 12MB cache, 1333 memory, 6.4 GT/s QPI, Six-Core, HT, Turbo
Operating System	Windows 8 Professional
Memory	4 GB
Hard Drive	1 TB, branded
Optical Drive	DVD+/- RW Dual Layer with Writer & writing software
Network	10/100 Network Card
Graphic Card	GPU Clock 750 MHz Memory 128-bit, 512 MB DDR5 Memory
Accessories	Color Printer , cordless mouse, keyboard, LCD 19" (All branded with minimum warranty of 6 months on individual part)

11. Equipment for linear slider (manual operation):

Linear motion slider:

Rod	Length - 50 cm	Aluminium
stator, flange, circular ring	Dia: 9.1 cm + 10mm/-10 mm	Aluminium

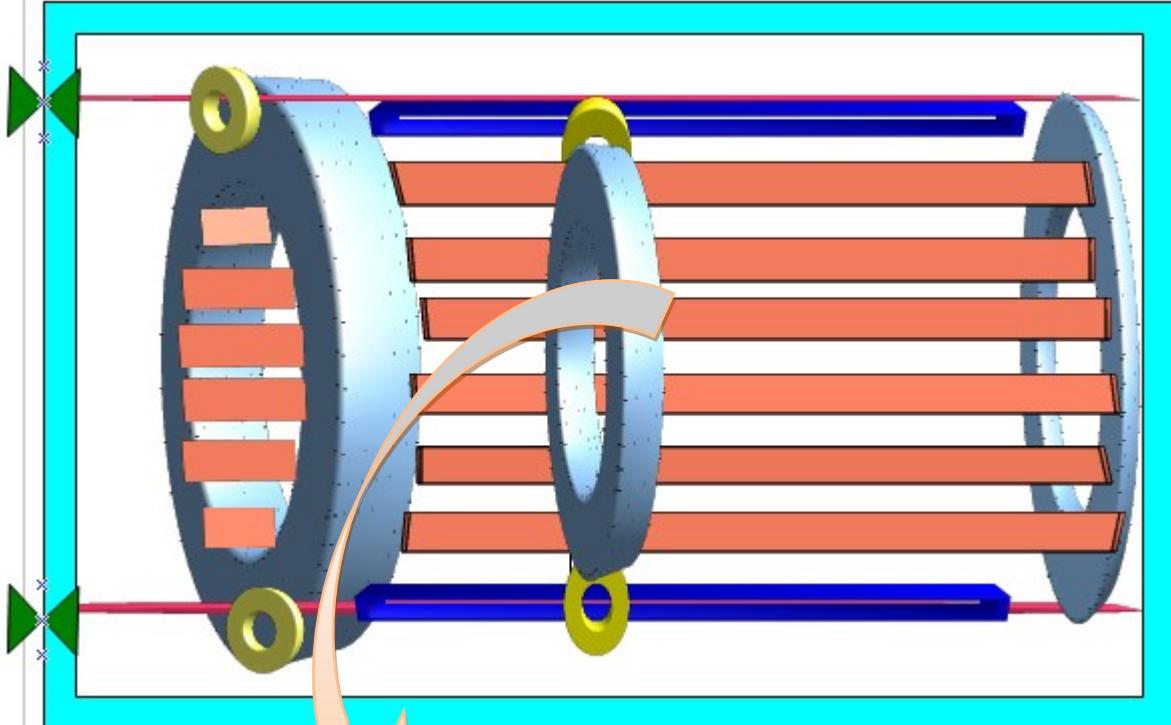

Block diagram of cross-section of detector arrangement outside plasma holding multicusp system

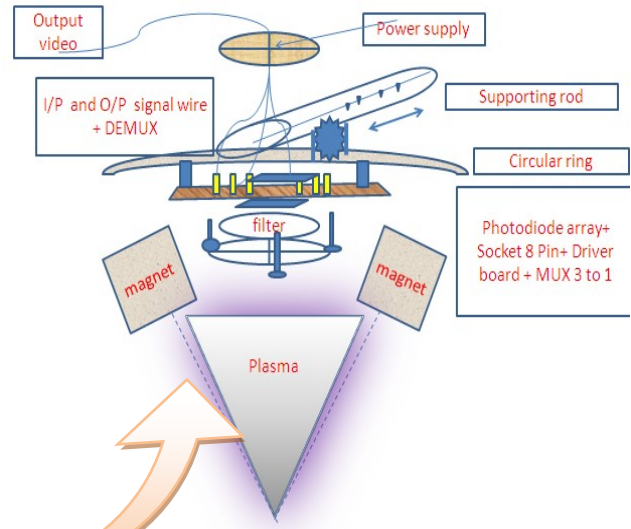
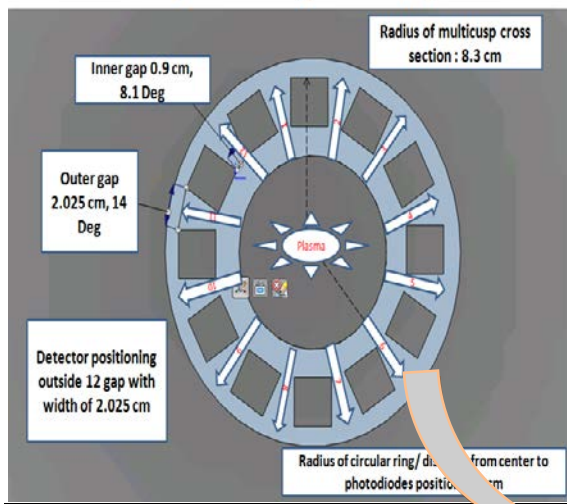

Block diagram of optical tomographic system

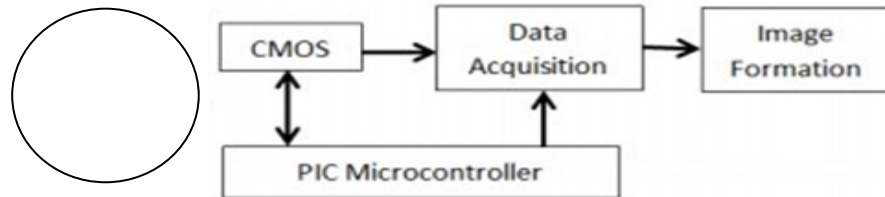

12. Consumable Unit:

Main expenses in consumable units are:

- Magnet for multiscusp
- Manufacturing cost for multiscusp
- Manufacturing cost for filter holder
- Installation cost
- Manufacturing cost for linear slider
- Gas cylinder of Ar and H₂

Note: The technical evaluation committee will decide to purchase the product irrespective of cost offered by the manufacturers and this will depend upon the availability of funds & technical specification and the usage of product in our institute.

1. Payment: As IITK standard terms.
2. Taxes: as applicable
3. Delivery: earliest possible time
4. Validity of quotation: 60 days.
5. Inspection: to be carried out at our place.
6. Please attach proprietary certificate if it is applicable.
7. Provision of Onsite Training.

8. Warranty one year.

(Prof P. Munshi)

Northern Block Laboratories

Department of Mechanical Engineering

Indian Institute of Technology-Kanpur-208016

Mail: pmunshi@iitk.ac.in

Phone: 0512-2597243

Head

Department of Mechanical Engineering

